



OWNER'S MANUAL

Read and understand this entire manual before allowing child to use this product! For assistance contact Razor. DO NOT RETURN TO STORE.

NOTE: Manual illustrations are for demonstration purposes only. Illustrations may not reflect exact appearance of actual product. Specifications subject to change without notice.

Please have your 22 character product I.D. code ready before contacting Razor for warranty assistance and/or replacement parts.

Product I.D. Code: _____ - _____ - _____

AN IMPORTANT MESSAGE TO PARENTS

This manual contains important safety information. For your child's safety, it is your responsibility to review this information with your child and make sure that your child understands all warnings, cautions, instructions and safety topics. We recommend that you periodically review and reinforce the information in this manual with younger riders and that you are required to inspect and maintain your child's caster board to insure their safety.

GENERAL WARNING:

Caster board riding can be a hazardous activity. Caster boards can, and are intended to move and it is therefore possible to get into dangerous situations and/or lose control and/or fall off. If such things occur you can be seriously injured or die.

LIKE ANY OTHER MOVING PRODUCT, USING A CASTER BOARD CAN BE A DANGEROUS ACTIVITY AND MAY RESULT IN INJURY OR DEATH EVEN WHEN USED WITH PROPER SAFETY PRECAUTIONS. USE AT YOUR OWN RISK AND USE COMMON SENSE.

- Always wear proper protective equipment. Elbow and kneepads, long sleeve shirt, gloves, long pants, shoes, and elbow and kneepads are recommended. Wear athletic shoes (lace-up shoes with rubber soles). Don't ride barefoot or in sandals. Keep shoelaces out of the way of casters and wheels.
- Use the caster board only on smooth, dry, level ground without loose debris, such as rocks or gravel.
- Never use the caster board at dusk or night or in wet or icy conditions.
- Avoid water, speed bumps, sand, gravel and anything else that could cause your wheels to stop. When in doubt, avoid the bumps.
- Do not exceed 220 lb (100 kg) total weight on the RipStik®, RipStik DLX and RipStik G caster boards. Do not exceed 175 lb (79 kg) total weight on the RipStik Ripster caster board.
- Do not allow children under age eight (8) to use the caster board. Children under age ten (10) should ride with adult supervision at all times.
- Never ride in traffic and watch your surroundings for pedestrians, bikes, skateboard and scooter riders. Use the caster board in areas free from fixed or moving hazards, such as poles, hydrants, parked automobiles and traffic.
- Risk of injury increases as degree of trick difficulty increases. Rider assumes all risk associated with trick riding activities. Be careful and know your limitations.
- This product was manufactured for performance and durability but it is not impervious to damage. Trick riding can over time stress or damage any product, including the RipStik, and the rider assumes all risks associated with high-stress activity.

FAILURE TO USE COMMON SENSE AND HEED THESE WARNINGS FURTHER INCREASES RISK OF SERIOUS INJURY. USE AT YOUR OWN RISK AND WITH APPROPRIATE AND SERIOUS ATTENTION TO SAFE OPERATION. USE CAUTION.

⚠ WARNING: ALWAYS INSPECT THE RIPSTIK PRIOR TO RIDING. Properly inspecting and maintaining your caster board can reduce the risk of injury. Always inspect your caster board before riding and regularly maintain it.

⚠ WARNING: REGARDING USE OF NON-RAZOR PRODUCTS WITH YOUR RIPSTIK CASTER BOARD. Your caster board has been built to our design specifications. All the original equipment supplied at the time of sale were selected on the basis of their compatibility with the frame, casters and all other parts. Certain after-market products may or may not be compatible with your RipStik caster board. Consult your retailer or contact us prior to modifying or replacing any component with a non-factory specified product.

⚠ WARNING: CHECK LOCAL LAWS REGARDING CASTER BOARD USE. Check local laws and regulations to see where and how you may use your RipStik caster board legally. In many states and local areas caster board riders may be required BY LAW to wear a helmet. Check local laws and regulations regarding laws governing helmet use and caster board operation in your area.

⚠ WARNING: Aggressive and other stunt-type riding reduce your ability to maneuver and control your caster board. Take the necessary precautions, such as wearing appropriate protective gear and practice in a safe area for stunt riding and free from obstructions.

⚠ WARNING: You will see people on TV and videos or maybe even people you know doing tricks or stunts on a caster board. These are people who have been practicing a long time and who accept the risks of trick riding activity. Do not assume that you can attempt to do the same tricks without great risk.

Need Help? Visit our web site for replacement parts, product support, a list of authorized service centers in the US and customer service contact information at www.razor.com. Please have the product I.D. code (located on the white label of your product) available for better assistance. Additional Customer Service contact information is listed at the back of this manual.

CASTER BOARD PARTS AND COMPONENTS

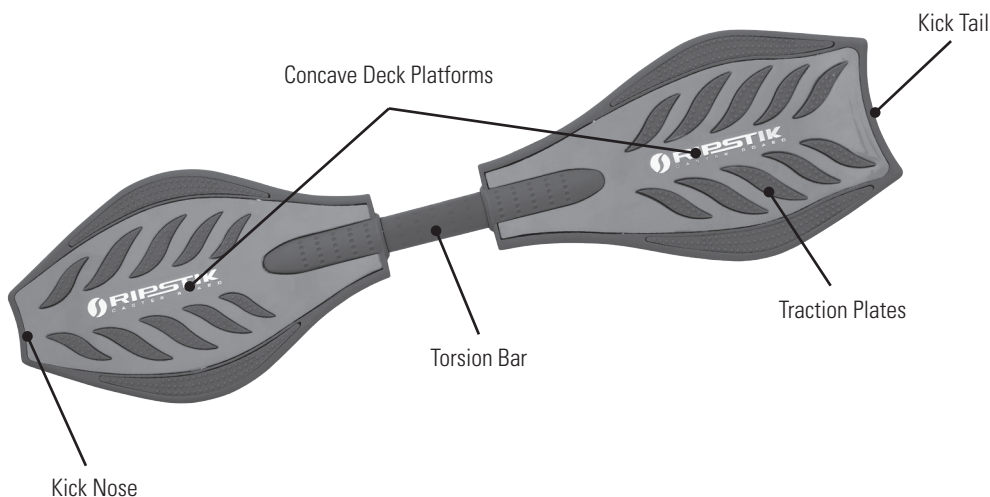

Product ID Locations:

1. Underneath platform
2. Box - side of UPC (not shown)

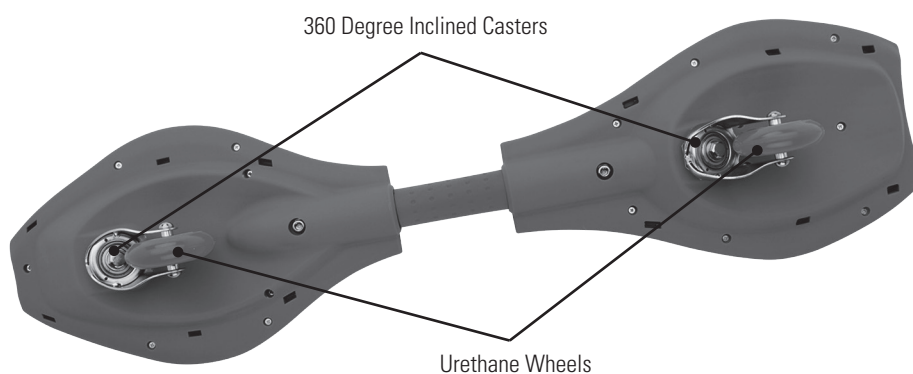

NOTE: Your model may differ in appearance from the one depicted above.

CHECK BEFORE RIDING

Always inspect your caster board's wheel bearings and other hardware to make sure they are tight before each use.

WHEELS AND BEARINGS

Under normal circumstances and conditions, RipStik wheels and wheel bearings are maintenance free. Nonetheless, it is the responsibility of the owner or guardian to periodically inspect the wheels for wear and tear, the axle for proper tightness, and the bearings for side-to-side play and loose parts.

When a wheel or wheel bearing develops play, this is an indication of excess wear and replacement is necessary. Replace immediately with only genuine RipStik wheels. Worn wheels/bearings are considered normal wear-and-tear and are not covered by the RipStik Limited Warranty. Wheels other than genuine RipStik wheels may not be compatible with your RipStik caster board. The use of anything other than genuine Razor replacement parts will void your warranty.

CLEANING YOUR RIPSTIK

Wipe with a damp cloth to remove dirt and dust.

Do not use industrial cleaners or solvents as they may damage the surfaces. Do not use alcohol, alcohol-based or ammonia-based cleaners as they may damage or dissolve the plastic components.

WARRANTY

Razor Limited Warranty

This Limited Warranty is the only warranty for RipStik caster boards. There is no other express or implied warranty.

The manufacturer warrants this product to be free of manufacturing defects for a period of six months from date of purchase. This Limited Warranty does not cover normal wear and tear, nor any damage, failure or loss caused by improper assembly, maintenance, storage or use of the caster board.

This Limited Warranty will be void if the product is ever:

- used in a manner other than for recreation or transportation;
- modified in any way;
- rented.

Check local laws and regulations to see where you can ride your caster board legally. The manufacturer is not liable for incidental or consequential loss nor damage due directly or indirectly from the use of this product.

The manufacturer is not liable for incidental or consequential loss or damage due directly or indirectly to the use of this product.

Razor does not offer an extended warranty. If you have purchased an extended warranty, it must be honored by the store at which it was purchased.

For your records, save your original sales receipt with this manual and write the serial number below.

CUSTOMER SERVICE CONTACT INFORMATION

Need Help? Visit our web site for replacement parts, product support, a list of authorized service centers in the US and customer service contact information at www.razor.com. Please have the product I.D. code (located on the white label of your product) available for better assistance. Additional Customer Service contact information is listed below:

AMERICAS

Razor USA LLC
P.O. Box 3610
Cerritos, CA 90703
USA

+1 866 467 2967
Monday - Friday
8:00 AM - 5:00 PM Pacific Time
customersupport@razorusa.com

DISTRIBUTED IN THE UK BY:

Re:creation Limited
2 Meadows Business Park
Station Approach, Blackwater
Camberley, Surrey GU17 9AB
United Kingdom

+44 (0) 118 973 6222 *Tel*
+44 (0) 118 973 6220 *Fax*
sales@recreationltd.co.uk

EUROPE

Razor USA LLC (Europe)
Handelsweg 2
2742 RD Waddinxveen
Netherlands

+44 (0) 120 267 2702
info@razoreu.com

DISTRIBUTED IN AUSTRALIA BY:

Funtastic Limited
Level 2, Tower 2, Chadstone Place
1341 Dandenong Road
Chadstone VIC 3148
Australia

+1 800 244 543
info@funtastic.com.au

ASIA

Razor USA LLC (Asia)
P.O. Box 3610
Cerritos, CA 90703
USA

+81 50 7579 6622
info@razor-asia.com

Printed in China for Razor USA LLC.

Copyright © 2003-2017 Razor USA LLC. All rights reserved. Razor® and the Razor logo design are among the registered trademarks of Razor USA LLC and/or its affiliated companies in the United States and/or select foreign countries. The RipStik™ is a trademark of Razor USA LLC and/or its affiliated companies in the United States and/or selected foreign countries.